

Hearts Keepsake Box

WP-608

Pattern by OTB Patterns

This is a fairly simple box you can make for just about any use. Adding the filigree cutout on the lid, and/or cut-outs on the sides and front can quickly change the character of this box. Visit www.otbpatterns.com for other designs that can be used on this box.

Use spray adhesive to attach Lid pattern to your material. Use 1/16" or 1/8" drill bit to cut holes for slipping scroll saw blade through. Cut out design, then carefully sand all rough spots.

Using the patterns for sizes and placement, cut out the rest of your box parts. Sand all parts.

Stain, or paint as desired. Slip front and back panels into bottom, add glue to side panels and slide into place. Clamp the box, making sure corners are square. Turn box upside down, and allow glue to dry. Before removing clamps, remove bottom, add glue and place back into position. Carefully clean off any excess glue.

Paint your sub top, or glue your fabric to your subtop, carefully smoothing out any wrinkles. With your lid upside down, add glue to top and carefully place subtop on lid making sure subtop is centered on lid. Clamp and let dry.

Once glue is dry, remove clamps and carefully place lid on box. sand as necessary to allow subtop to slip into place in the box. Do not force the lid.

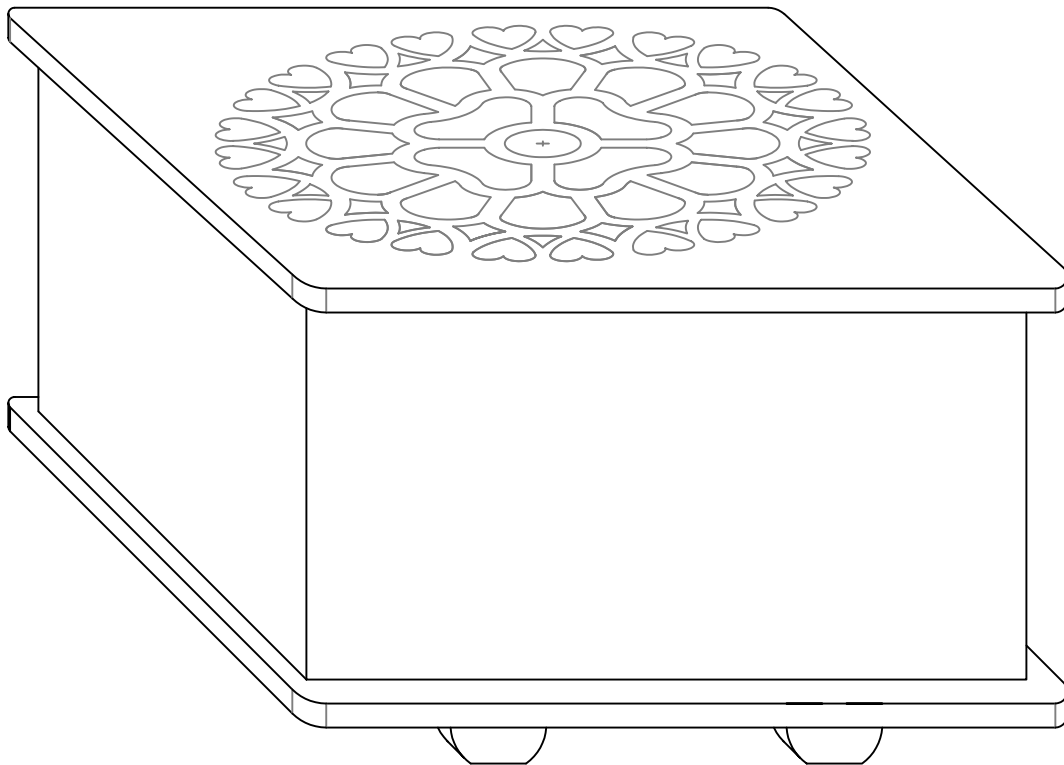

Finished size: 8" x 8" x 5 1/8" Tall. Adjust pattern as necessary for other sizes.

Top - Lid

Visit www.otbpatterns.com for other interesting designs to use on your project

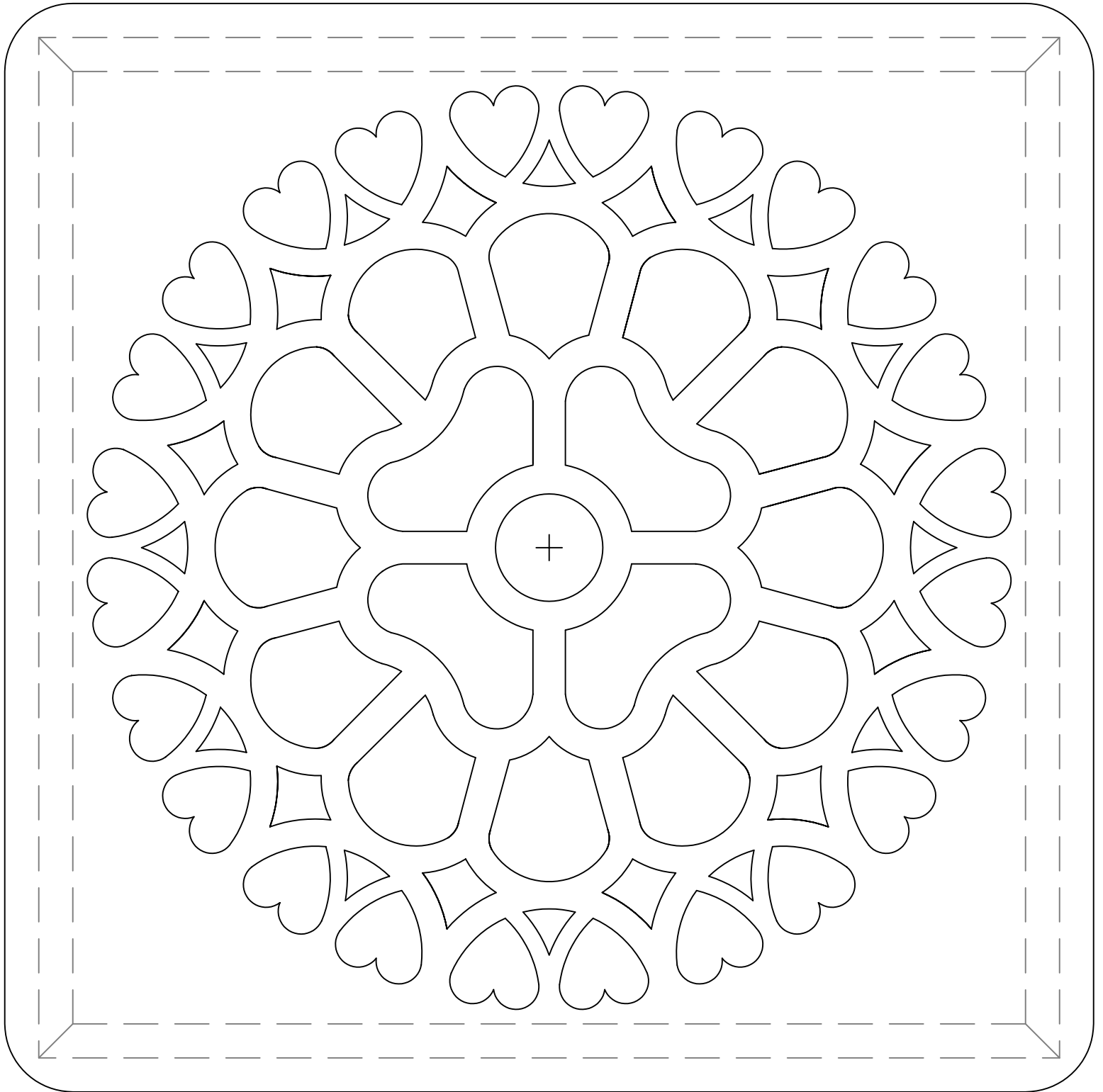

Broken lines indicate position of box. Inside set of broken lines indicates position of sub-top when glued to top.

Front / Rear panels (cut 2)
Mitre two inside ends.

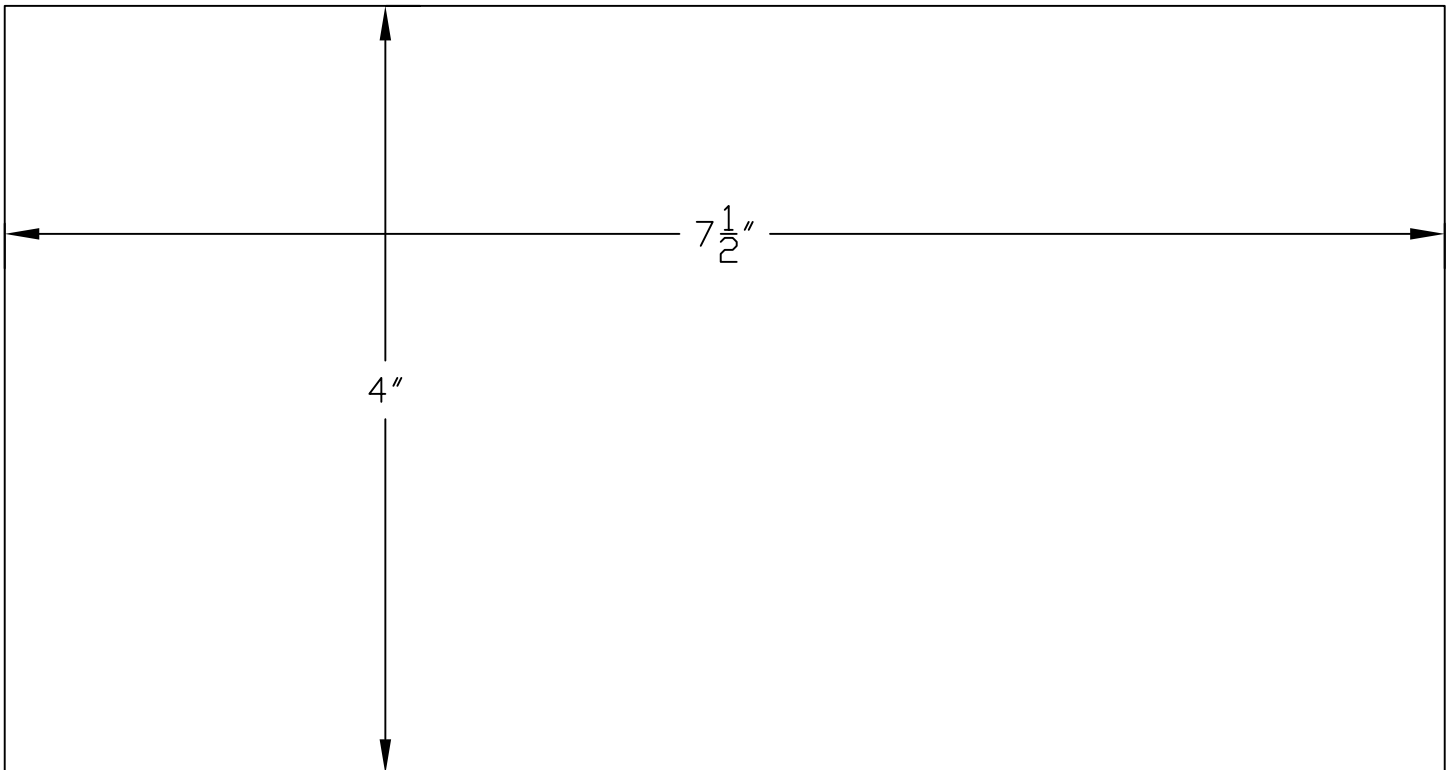
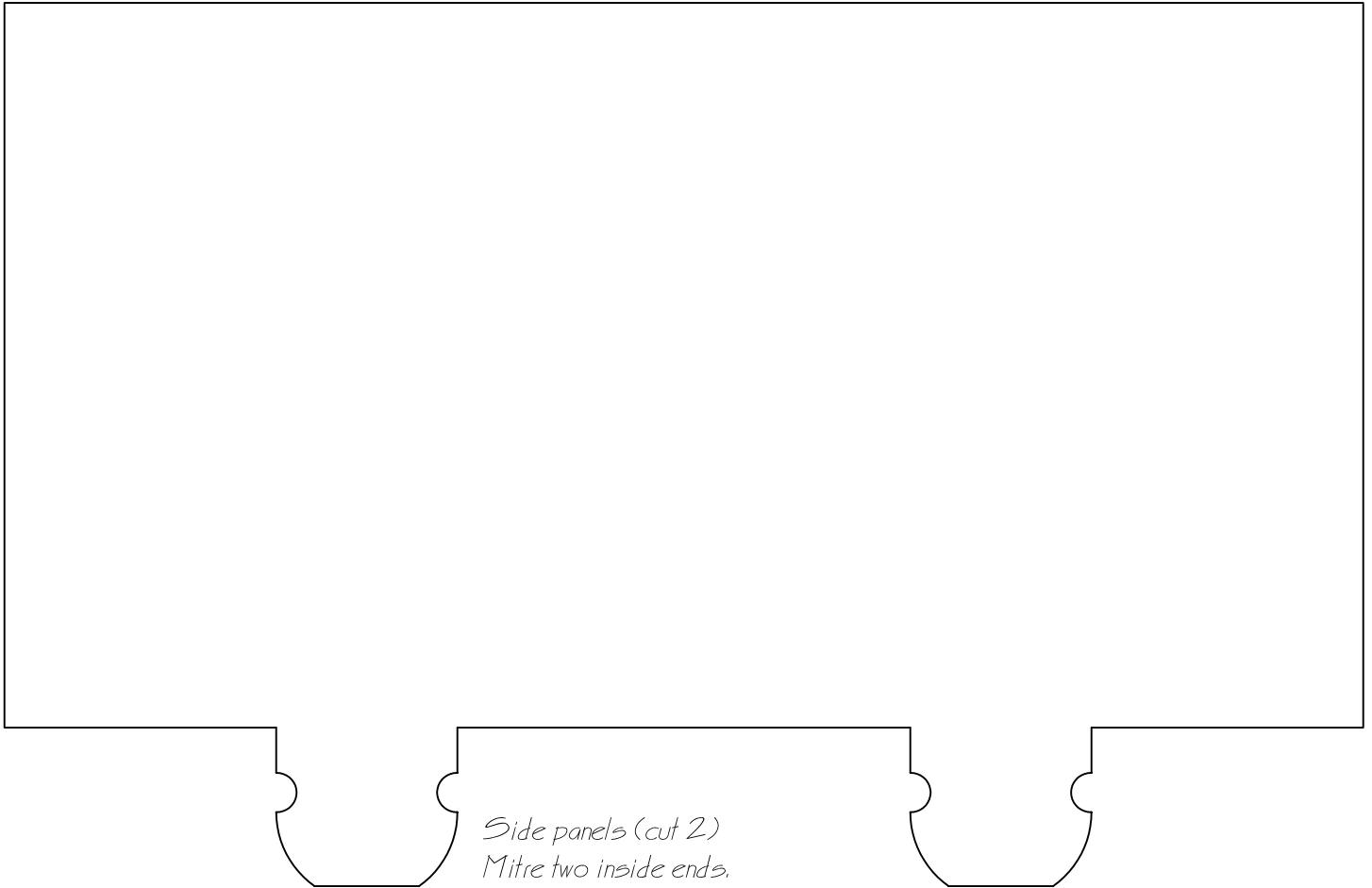

Bottom

Note: adjust slots as required for material thickness.

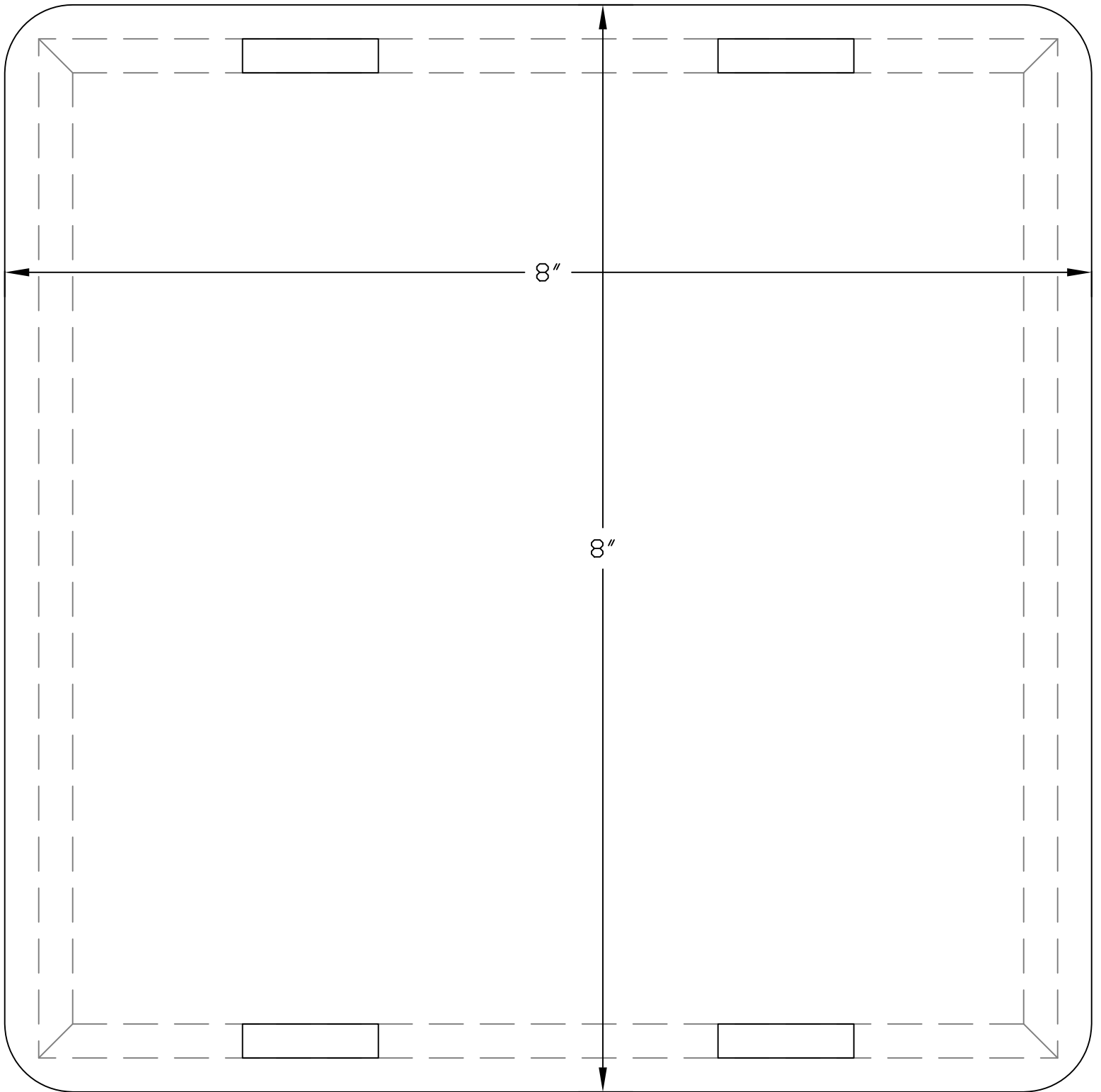

Broken lines indicate position of box when attached to bottom.

Sub Top: Attach Velvet, felt, or other fabric or leather to the sub top, then attach to the back of the TOP. Or stain or paint contrasting color prior to gluing to the TOP.

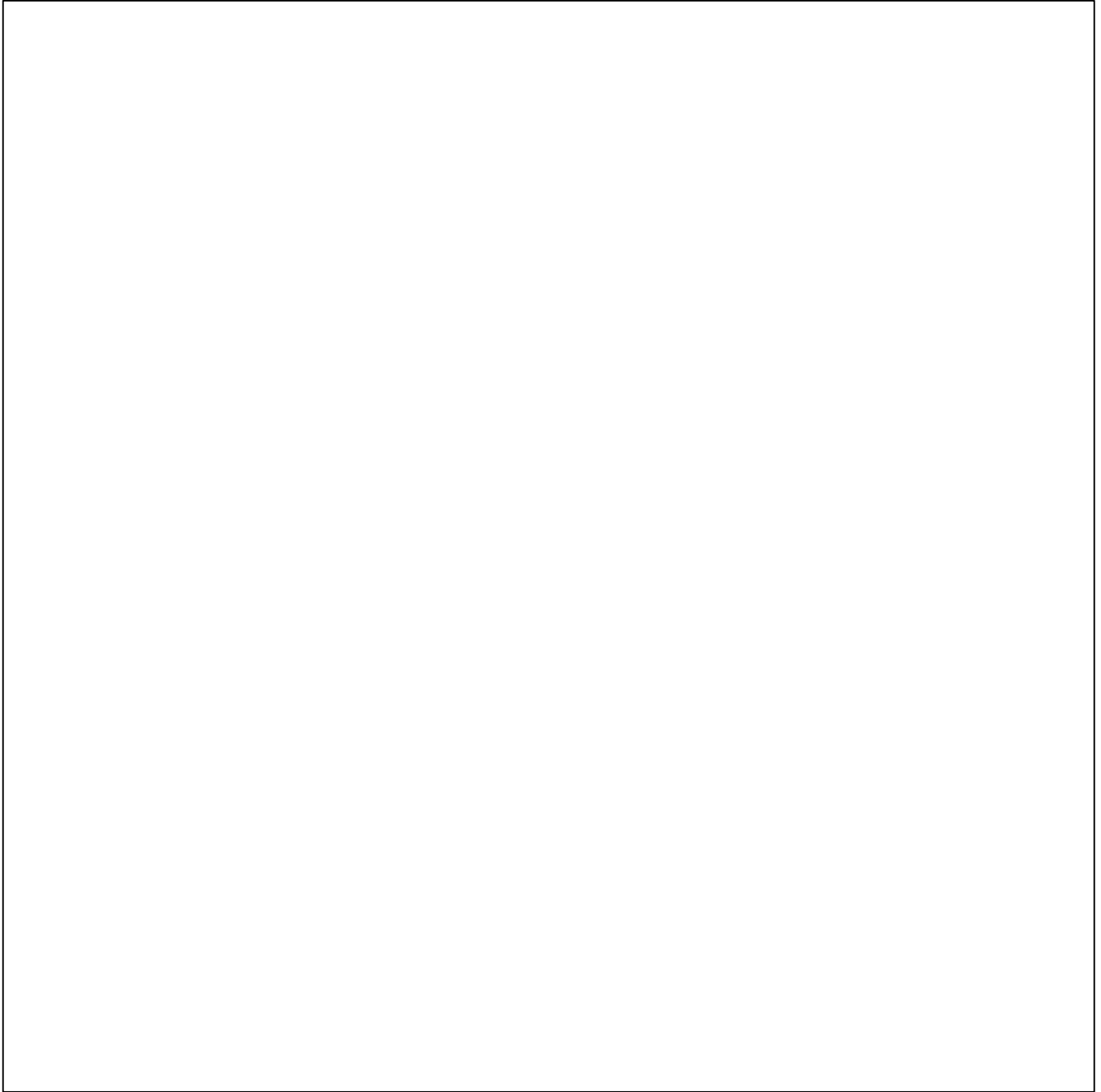

Sub Top / Inside of box = 7" x 7"

Bonus Plans
Front / Rear panels (cut 2)
Mitre two inside ends.

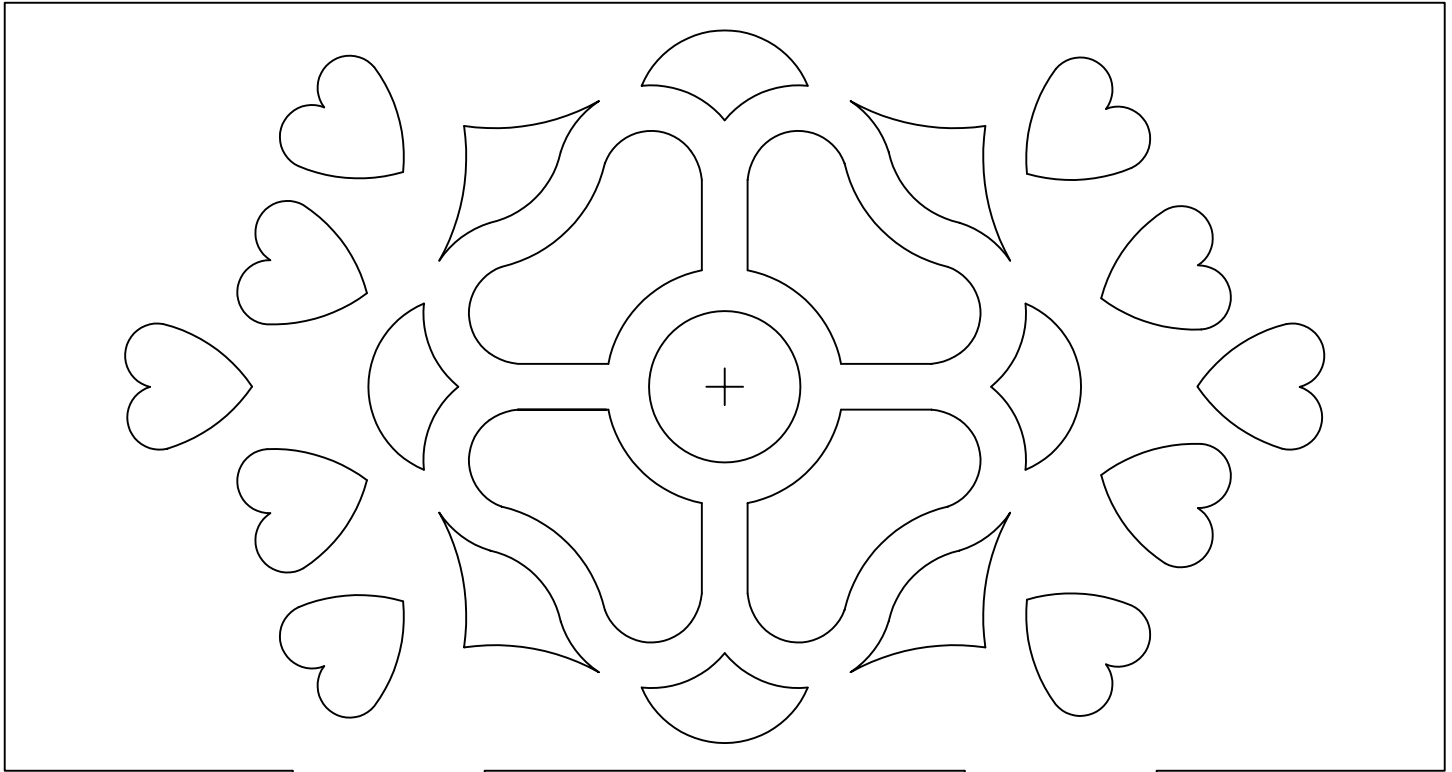

Bonus Plans
Side panels (cut 2)
Mitre two inside ends.

